

GE Infrastructure
Water and Process Technologies

Merlin™
Point of Use
Drinking Water System

Installation and Maintenance Manual



SAFETY GUIDES

Read and follow all steps and guides carefully before installing and using your reverse osmosis system.

Do not use this product to make safe drinking water from non-potable water sources. Do not use the system on microbiologically unsafe water, or water of unknown quality without adequate disinfection before or after the system.

This reverse osmosis system contains replaceable components (membrane elements). These components are critical for the effective reduction of total dissolved solids and specific contaminants that are listed in the Appendix.

The Merlin drinking water system does not have a monitoring device for contaminants. To verify that the system is performing satisfactorily the product water should be tested periodically by the system's installing dealer every six months. See the back cover of this manual for the installing dealer's contact information.

Consult your local public works department for plumbing and sanitation codes. Follow your local codes if they differ from this manual.

The reverse osmosis system works on water pressures of 40 psi (2.8 bar) minimum to 80 psi (5.5 bar) maximum. Water pressure can be reduced by installing a pressure reducing valve in the water supply pipe to the RO system. A booster pump should be used for low pressure applications.

Do not install the reverse osmosis system in extreme hot or cold temperatures. Temperature of the water supply to the reverse osmosis system must be between 40°F (°C) and 100°F (38°C). Do not install on **hot** water lines.

The reverse osmosis membranes contain a foodgrade preservative for storage and shipment. **New membranes should be flushed for one hour prior to use.** This flush removes the preservative. The preservative is not harmful but makes the product water taste objectionable.

THE BASIC REVERSE OSMOSIS SYSTEM

Your Merlin™ Reverse Osmosis (RO) Drinking Water System is a water treatment unit. It uses water pressure to reverse a natural physical process called *osmosis*. Water, under pressure, is forced through a semi-permeable membrane to filter out minerals and impurities. Clean drinking water goes to the faucet. Minerals and impurities are sent to the drain with RO waste water.

The system includes replaceable filters and membrane elements. The prefilter removes sand, silt, dirt, rust particles, other sediments, and chlorine from the water supply before they enter the RO membrane elements. The postfilter removes any tastes and/or odors that may remain in the water after passing through the RO membrane elements.

BEFORE INSTALLING THE RO SYSTEM

- Best performance of the system will be achieved when the incoming water has been treated (softened).
- The water coming into the system must be within certain limits for sediments, pressure, etc. Refer to the specifications to determine if your installation is within the limits.
- A water quality analysis can be performed to determine if incoming water requires any treatment. Contact your dealer/installer.
- The filters and membrane elements in the RO system need to be replaced on a regular basis. Follow the instructions for replacement that are in this manual.



NOTE: For optimal system performance, use the system for at least 2 minutes continuously each day.



WARNING: The Merlin RO system is designed to work without the aid of a storage tank. **DO NOT** connect a pressurized storage tank to the Merlin permeate line. Damage to the system may occur if a pressurized storage tank is used with the Merlin RO system.

REVERSE OSMOSIS PACKAGE

The reverse osmosis system is purchased as an installation kit. Before starting installation check that the following components are available:

Quantity	Item	Part Number
1	Manifold	1244617
1	Support Leg	1239708
1	Locking Bar	1239731
1	Disconnect Elbow and O-ring—Flush Mechanism	1240119
1	1/4-inch Collet Lock Clip	1240626
1	1/4-inch Plug	1240624
1	Disconnect Elbow and O-ring— Feed Water	1240117
2	1/2-inch Collet Lock Clip	1240628
1	Disconnect Elbow and O-ring—Concentrate Stream	1240116
1	Disconnect Elbow and O-ring—Permeate Stream	1240118
5	3/8-inch Collet Lock Clip	1240627
3	White Sumps	1239705
3	Sump O-ring	1240326
2	Lubricant, Silicone	1013501
1	3/8-inch Tube-To-Threaded Tubing Connection	1240625
Tubing		
4 feet	1/2-inch Natural Color Inlet	1240622
4 feet	3/8-inch Blue Color Product	1240621
4 feet	3/8-inch Black Color Concentrate	1240620
3 feet	1/2-inch Red Color Drain	1240623
Faucet Kit		
1	Faucet and Air Gap	1254894
Drain Connection		
1	Packaged Drain Boa Kit	1240564
Filters		
2	Membrane Elements	1238342
1	White Carbon Prefilter	1237460
1	In-Line 3/8-inch Carbon Post Filter	1244746



NOTE: The system inlet (feed water) connection/valve is not included in the standard package. Contact your system supplier.

LOCATION OF SYSTEM

The reverse osmosis system is designed for installation under a sink, usually in the kitchen or bathroom. The RO assembly can be placed on the cabinet floor in any position that does not apply pressure on the disconnect elbows. The RO product water faucet installs on the sink or on the countertop next to the sink.

The RO system can also be located in a location away from the faucet. A nearby water source and drain point are required.



NOTE: Keep the lengths of tubing short. Longer lengths of tubing will decrease system performance. A booster pump can be used on the supply line.

Water Supply: To provide supply water to the RO system inlet, a feed supply fitting is required or install pipe fittings as needed.

Drain Point: A suitable drain point is needed for reject water from the RO system. A floor drain, laundry tub, standpipe, sump, etc. are all acceptable. A sink p-trap drain adapter is included to install as an optional drain point where codes permit.

All components and tubing should be located in an area which is not exposed to freezing temperatures. Do not expose unit or tubing to direct sunlight.

Dispensing Faucet: The faucet should be placed near the sink where drinking water is normally obtained. Convenience of use (filling of water pitchers and glasses) and an open area beneath the faucet under the sink for attaching product and drain tubing are considerations. A 2-inch diameter flat surface is required above and below the installation site. The thickness of mounting surface should not exceed 1-1/4 inches. Avoid any strengthening webbing on the underside of the sink.

RO Manifold Assembly: The manifold can be installed on either the right or left side of the under-sink area or cabinet. Installation in the basement is also an option. One possible location is near the laundry/utility sink where cold potable water and drain access are close. The location chosen should allow adequate clearance and accessibility for membrane element changes.

Feed Water Connection: The feed water valve should be located as close to the manifold assembly as possible. **USE A POTABLE COLD WATER SUPPLY ONLY.** Softened water is preferred as it will extend the life of the RO membrane element.



NOTE: The feed water connection is not included in the package.

Drain Connection - Depending on plumbing codes, the waste water may need to go to drain through an anti-siphon air gap. A detachable faucet air gap is included with the system. If discharging into the utility sink or standpipe, an air gap of greater than 1.5 inches above the flood rim must be provided.

Do not connect the system drain line to the dishwasher drain or near the garbage disposal. Back pressure from these units may cause the air gap to overflow.



NOTE: All plumbing should be done in accordance with state and local plumbing codes.

Some codes may require installation by a licensed plumber; check with the local plumbing authority prior to installation.

In restricted under-sink areas, it may be easier to install the faucet first. Allow adequate tubing lengths for final system placement.

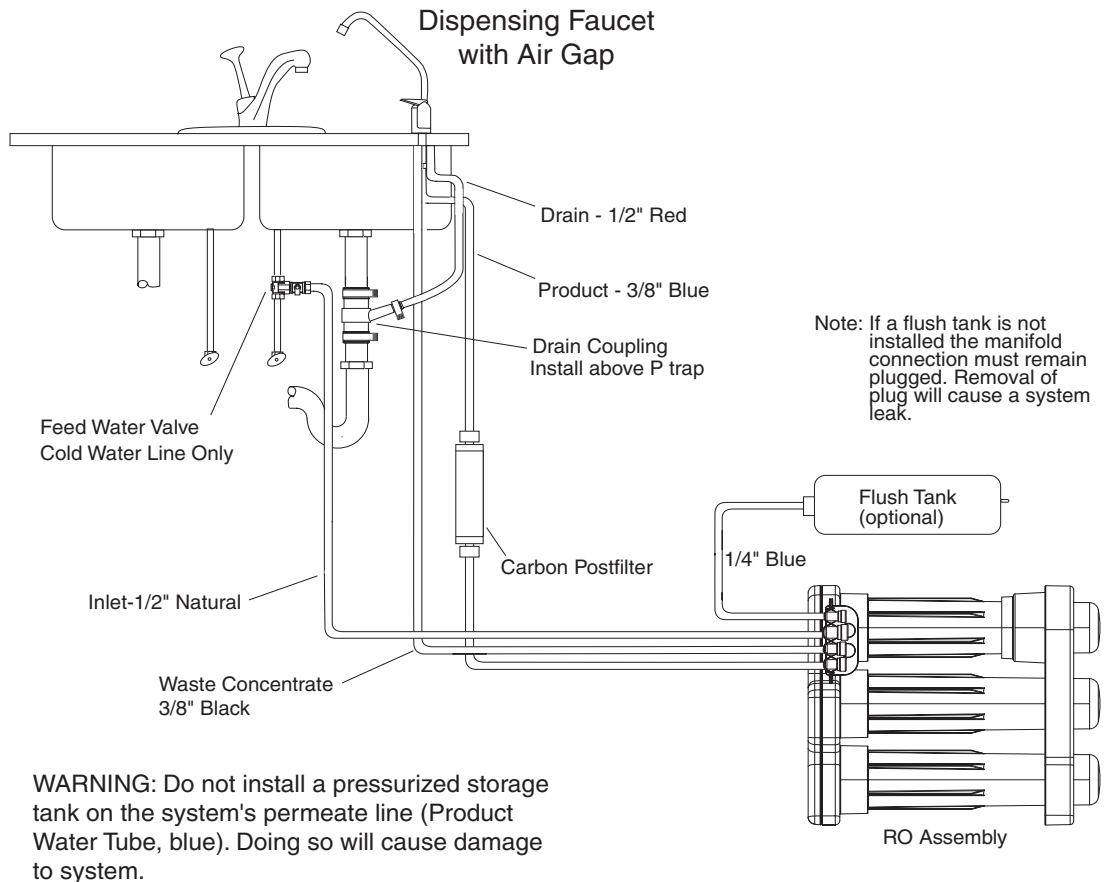

Figure 1 Typical Under-Sink Installation

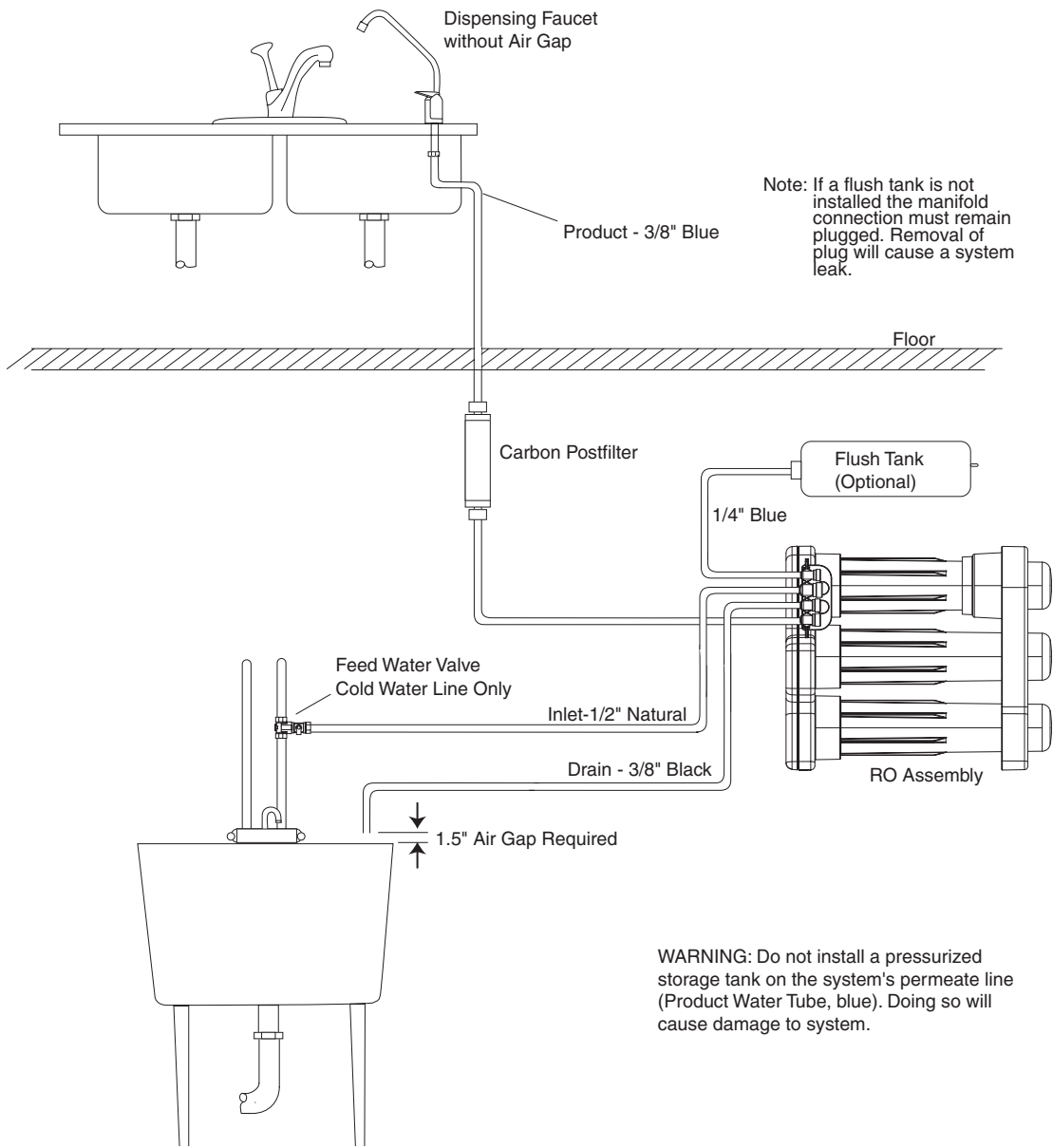

Figure 2 Typical Basement Installation

REQUIRED TOOLS AND MATERIALS

- Adjustable wrench, and larger adjustable jaw pliers or pipe wrench to fit sink drain
- Saw for cutting drain pipe
- Slotted and Phillips head screwdrivers
- Tubing cutters
- Electric drill and bits for cutting the faucet mounting hole

Note that some sinks will have a pre-drilled hole with a plug for the faucet.

INSTALLATION

STEP 1: Install cold water supply valve

STEP 2: Install drain adapter

STEP 3: Install faucet

STEP 4: Make tubing connections

STEP 5: Install RO assembly

STEP 6: Put system into operation



NOTE: Consult a licensed plumber if you are not familiar with plumbing procedures.

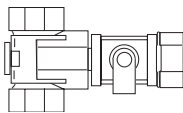

STEP 1: INSTALL COLD WATER SUPPLY VALVE

Comply with local plumbing codes. A typical connection using a water supply valve is shown. The feed water valve is not included with system. Contact supplier for this item.

Water Supply Valve



NOTE: Be sure to turn off the water supply and open a low faucet to drain the pipe.

Cold water pipes vary in size and style. The installer will determine type of valve that will be used. Install a valve on the cold water supply pipe to adapt 1/2-inch OD tubing. If threaded fittings are used, be sure to use pipe joint compound or Teflon tape on outside threads.

Turn the valve off.

STEP 2: INSTALL DRAIN ADAPTER

Follow the instructions in the Appendix for installation of the Drain Boa™.

The drain adapter is designed to fit 1-1/2-inch (3.8 cm) sink drain pipe. The adapter installs directly to the sink tailpiece.

STEP 3: INSTALL FAUCET

A. Prepare Mounting Hole

1. Select a location for the faucet. Be sure it will fit flat against the sink or counter and that there is space underneath for tubing.
2. If drilling is needed, make a 1-1/8-inch to 1-1/4-inch diameter hole.



WARNING: To avoid damaging a sink, consult a qualified plumber or installer for the proper method of drilling holes in porcelain or stainless steel.

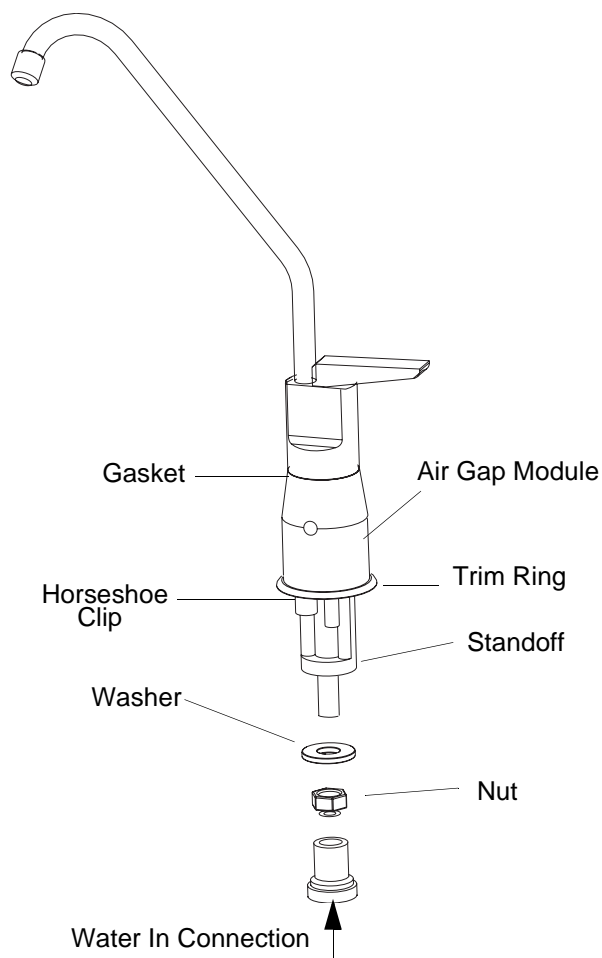

Figure 3

B. Assemble Faucet

The tubing and fasteners are assembled to the faucet before the faucet is placed in position. If not using the air gap module, skip to step #3.

1. If the air gap feature is used, place the gasket in position on the faucet.
2. Add the air gap module.
3. Slide the decorative ring over the tubing connections and up to the bottom of the faucet.
4. Slide the standoff onto the threaded tube, followed by the standard washer and nut.
5. Screw the threaded hose connector on the end of the threaded tube.
6. Connect the blue 3/8-inch product tubing by firmly pushing it into the connector.
7. If using the air gap module, push the black 3/8-inch tubing onto the small hose barb from the collar. The red 1/2-inch tubing is pushed onto the large hose barb.
8. Put the faucet into position.
9. The horseshoe clip is positioned around the threaded pipe under the sink and above the standoff.
10. Tighten the nut against the clip to hold the faucet in position.

STEP 4: MAKE TUBING CONNECTIONS

The connections to the faucet should be complete, the remaining connections are:

- Feed connection—clear tubing from feed valve to white elbow connector
- Drain connection—either red tubing from the air gap or black tubing from grey elbow connector will attach to the drain adapter
- Permeate connection—blue tubing from faucet to blue elbow connection
- To the flush tank (if used)
- Attach the fittings to the manifold

A typical connection is shown in Figure 4.

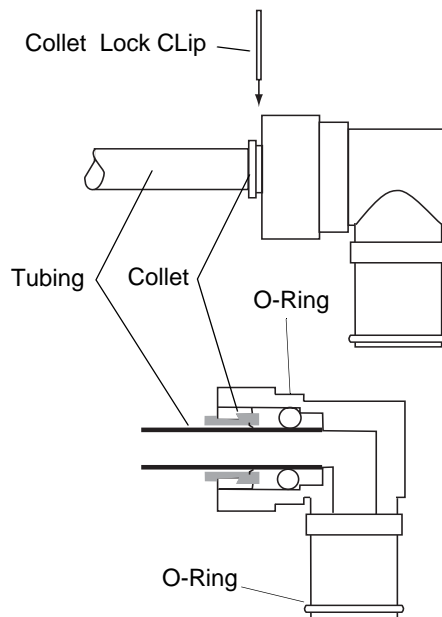

NOTE: Make sure the tubing is pushed past the O-rings for a secure fit. Also, when replacing any tubing, cut tubing back ~1/4 inch prior to re-inserting to prevent leaks.

Figure 4 Side View and Cutaway of Tubing Fitting



NOTE: For optimal system performance, we recommend using tubing lengths that are as short as possible.

Postfilter

Install the postfilter inline with the blue permeate tubing. Secure tubing with collet lock clips.

Drain Adapter

The drain adapter has a rubber inlet that accepts the 3/8-inch black drain tube or the 1/2-inch red tube. The 3/8-inch black tubing will connect here if the faucet is not using the air gap module.

When the tubing is in position, use the supplied hose clamps to secure the connection.



NOTE: When sliding tubing into the drain adapter inlet, wet the tubing. Water will help the tubing slide into the rubber inlet.

Feed Water Valve (Not Supplied)

The feed water valve attaches to a nearby cold water supply line. The installer will determine the type and size of valve that will be installed. This valve connects to the 1/2-inch natural tubing.

Flush Tank (Optional)

If the flush tank is used, the 1/4-inch blue tubing will be used to connect to the top fitting of the RO assembly manifold. Remove the plug and push the tubing into the fitting until it stops.



CAUTION: If the flush tank is not used, the 1/4-inch fitting on the manifold must be plugged or water will leak out.

STEP 5: INSTALL RO ASSEMBLY

The RO Assembly includes the following components: sumps (3), support leg, prefilter, RO membrane elements (2), and postfilter. The tubing is attached to the manifold by the elbow connectors. When choosing a location for the system, allow enough tubing for it to be moved for periodic servicing of the filters and membrane elements.

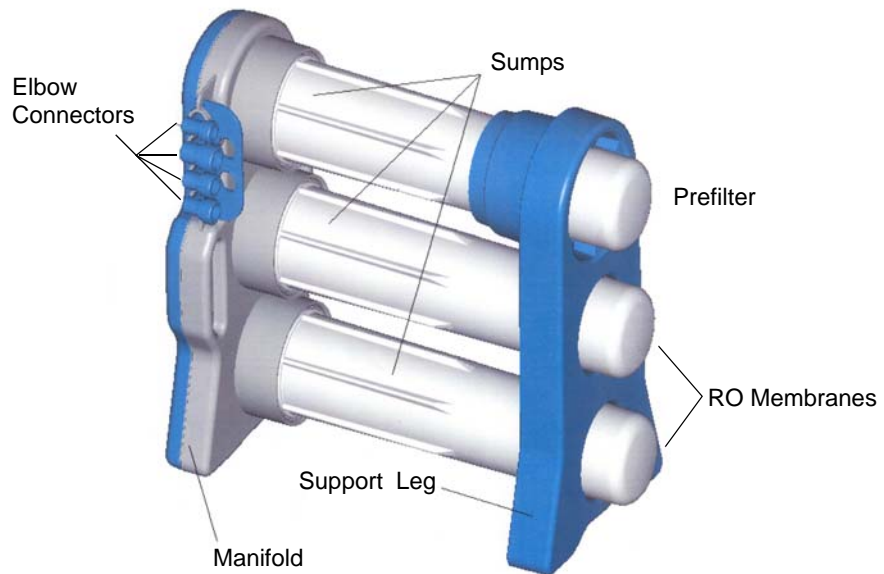
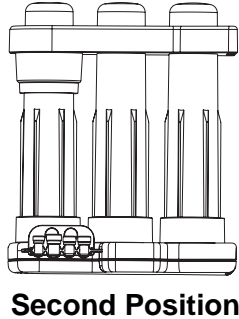
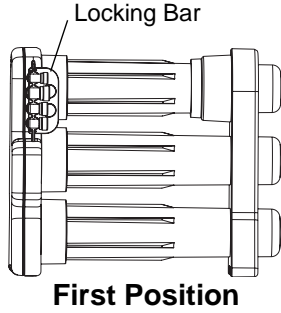

Figure 5 Merlin RO Assembly



WARNING: Do not attempt to mount/hang the Merlin. Do not try to drill mounting holes anywhere on the system. If putting above ground/cabinet level, a sturdy, permanent shelf is recommended.

Recommended Placement Positions



The Merlin assembly should be positioned in one of two ways.

The first position is with the unit standing upright using the support leg with the sumps horizontal. The tubing is directed to provide the best fit.

The second position, sets the unit on end so the manifold is horizontal and the sumps are pointing up. The tubing is directed upward and the locking bar is down to lock the tubing connections.

See illustrations at left.

The table below shows the coding system for the fitting connections. Each fitting has a unique “keyed” socket on the manifold. Each fitting also has a graphic symbol molded into the elbow with a corresponding symbol on the manifold.

Connector Symbol	Connection	Tubing Color
○	Flushing (optional)	Blue
←	Feed-Inlet	Natural
△	Concentrate	Black
□	Product	Blue



WARNING: Be sure to lubricate the O-rings on the fitting elbows prior to inserting into manifold.



WARNING: Do not turn the incoming water valve on until the locking bar is in place.



NOTE: If the installation is not using the optional flush tank, the top connection will not have tubing. Instead a plug will be inserted into the fitting. Do not remove plug unless you are attaching the tubing and the flush tank.

When all of the connections have been made, use the locking bar to hold the fittings in position. Match the symbols on the locking bar to the corresponding symbols on the manifold.

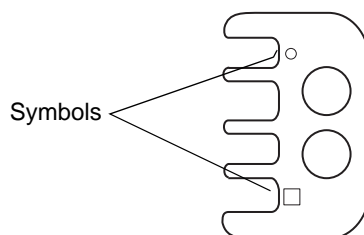

Figure 6 Locking Bar

STEP 6 SYSTEM STARTUP

1. Inspect all connections.
2. If the flush tank is not installed, the 1/4-inch port on the manifold must be plugged.
3. Position manifold horizontal with openings facing up.
4. Remove new membrane elements from packaging.



CAUTION: Elements contain a foodgrade preservative. The use of sterile/latex gloves is recommended.

5. Lubricate element O-rings, brine seals, and sump O-rings with silicone lubricant.
6. Securely insert O-ring end of membrane elements into manifold.
7. Remove carbon/sediment prefilter from packaging. Check that gaskets are in place.
8. Place carbon filter in manifold.
9. Replace sumps and hand-tighten.

Pressure Test System

To check for leaks, the system must be filled with water and brought up to operating pressure.

1. Open cold water feed valve slowly. Run at 1/2 open for a minute, then open fully.
2. Open faucet until water runs.

3. Check for leaks.



NOTE: When the faucet is initially turned on, water may temporarily sputter from the air gap until the air is purged. Allow 1 to 3 hours for any trapped air noise in the system to subside.

4. Purge the system. Open the faucet and run the water through the RO system for one hour.



NOTE: The one hour flush removes a food grade preservative from the membrane elements. It is not harmful but may affect the taste of the water.

The RO system is now ready for use.

TO CARE FOR THE RO SYSTEM

The components of the RO system are designed to function with minimal maintenance. However, the membrane elements and filters will need to be replaced on a regular schedule.

Run the system for at least two minutes each day for optimal performance.

REPLACEMENT OF PREFILTER AND POSTFILTER

The carbon/sediment prefilter removes sediment and certain chemicals, such as chlorine, from the water. Depending on water use and the amount of impurities, this filter should be replaced every six to twelve months.

Whenever the prefilter is replaced, the postfilter should also be replaced.

REPLACEMENT OF RO MEMBRANE ELEMENTS

The functional life of the RO membrane elements will vary based on feed water quality. Product water should be tested periodically to verify the membrane elements are performing properly. For most residential applications, the RO membrane elements should be replaced every two to four years.



NOTE: Softened water is recommended for optimal system performance and RO membrane element life.

REPLACEMENT OF THE PREFILTER, POSTFILTER, AND RO MEMBRANE ELEMENTS

1. Turn off the water supply to the RO System.
2. Reduce system water pressure by opening the faucet.



CAUTION: Even with the water supply turned off the membrane and prefilter sumps will contain a considerable amount of water. By positioning the RO assembly in a sink or tub, most of the water will be contained.

3. Disconnect locking bar and place the fittings (with tubing still connected) into a tub or bucket.
4. Move system into a contained area, such as a sink or tub.
5. Remove the support leg from the three sumps and unscrew the top sump as shown to access the prefilter element. The support leg functions as a wrench to loosen the sump, Figure 7.

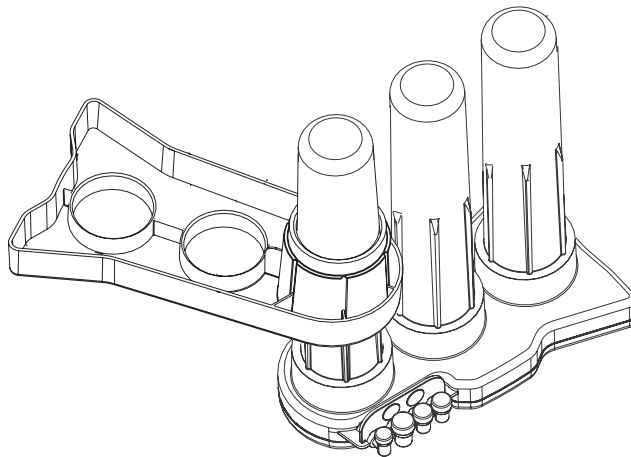

Figure 7



NOTE: There is no need to disconnect tubing from fittings on the manifold. Remove locking bar and pull fittings out. Lubricate O-rings with silicone prior to re-assembly.



NOTE: If changing only the prefilter and postfilter, the other sumps do not need to be removed.

If changing the membrane elements, the prefilter and postfilter should also be changed.

6. Remove exhausted prefilter and discard.



CAUTION: The person handling the filters and membrane elements must have clean hands to keep the system sanitized. The use of sterile/latex gloves is recommended.

7. If Changing Membrane Elements:

- A. Remove membrane sumps. Remove and discard used elements.
- B. Remove new elements from packaging.



CAUTION: Elements contain a foodgrade preservative. The use of sterile/latex gloves is highly recommended.

- C. Lubricate element O-rings, brine seals, and sump O-rings with silicone lubricant.
- D. Securely insert O-ring end of elements into manifold. See Figure 8.
- E. Replace sumps and hand-tighten.



NOTE: The system should be sanitized whenever a membrane element or filter is replaced.

8. Sanitize the system.

- A. The manifold should be positioned flat with the sump connections facing up.

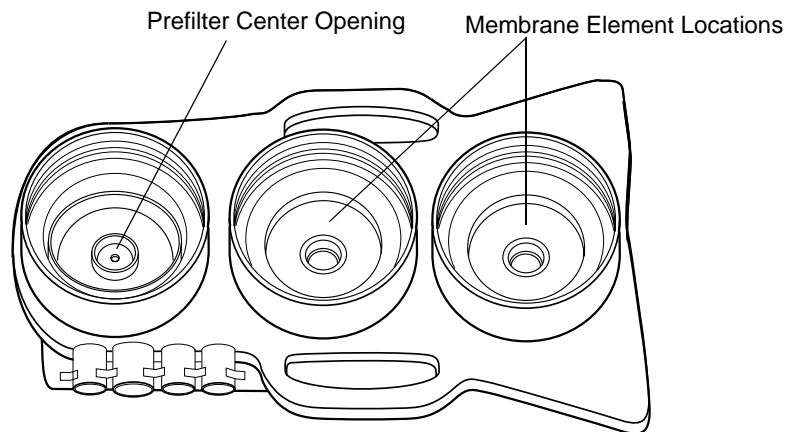

Figure 8

B. Pour a tablespoon (15 milliliters) of chlorine bleach into the center opening of the prefilter sump connection. See Figure 8.

9. Install prefilter.

A. Remove new prefilter from packaging. Ensure gaskets are secure. Insert prefilter into proper opening on manifold.

B. Lubricate sump O-ring with silicone lubricant.

C. With the prefilter element in place, screw the sump into the connection. Do not overtighten.



NOTE: The sumps are sealed using an O-Ring. Tighten by hand. If any leaks are detected when water pressure is applied, the sumps can be tightened further.

10. Replace the postfilter.

A. To unlock the fittings from the tubing, push down on the collet sleeves and pull the tubing out.

B. Discard the exhausted postfilter.

C. To prevent leaks, cut the tubing back approximately 1/4 inch prior to connecting the new postfilter. Make sure flow direction arrow aligns with water path. Reinsert tubing and collect locks.

11. Re-connect the fittings to the manifold and lock in position with locking bar.

12. Re-position the assembly and turn the water supply on. Check the system for any leaks.



CAUTION: When the faucet is opened, water may sputter from the air gap until the trapped air is purged.

13. Open the faucet and run water for two minutes.



NOTE: Carbon fines may be present until the postfilter element is flushed out.

14. Shut off the faucet and allow the system to stand idle for 20 to 30 minutes.

15. Open the faucet and run water for two minutes or until chlorine odor is gone.

16. Check for any system leaks.



NOTE: If the two RO membrane elements were replaced the system should be flushed for one hour. This flush removes the food grade preservative from the elements. The preservative is not harmful but may affect the taste of the water.

The RO system is now ready for use.

APPENDIX

MERLIN COMPONENTS

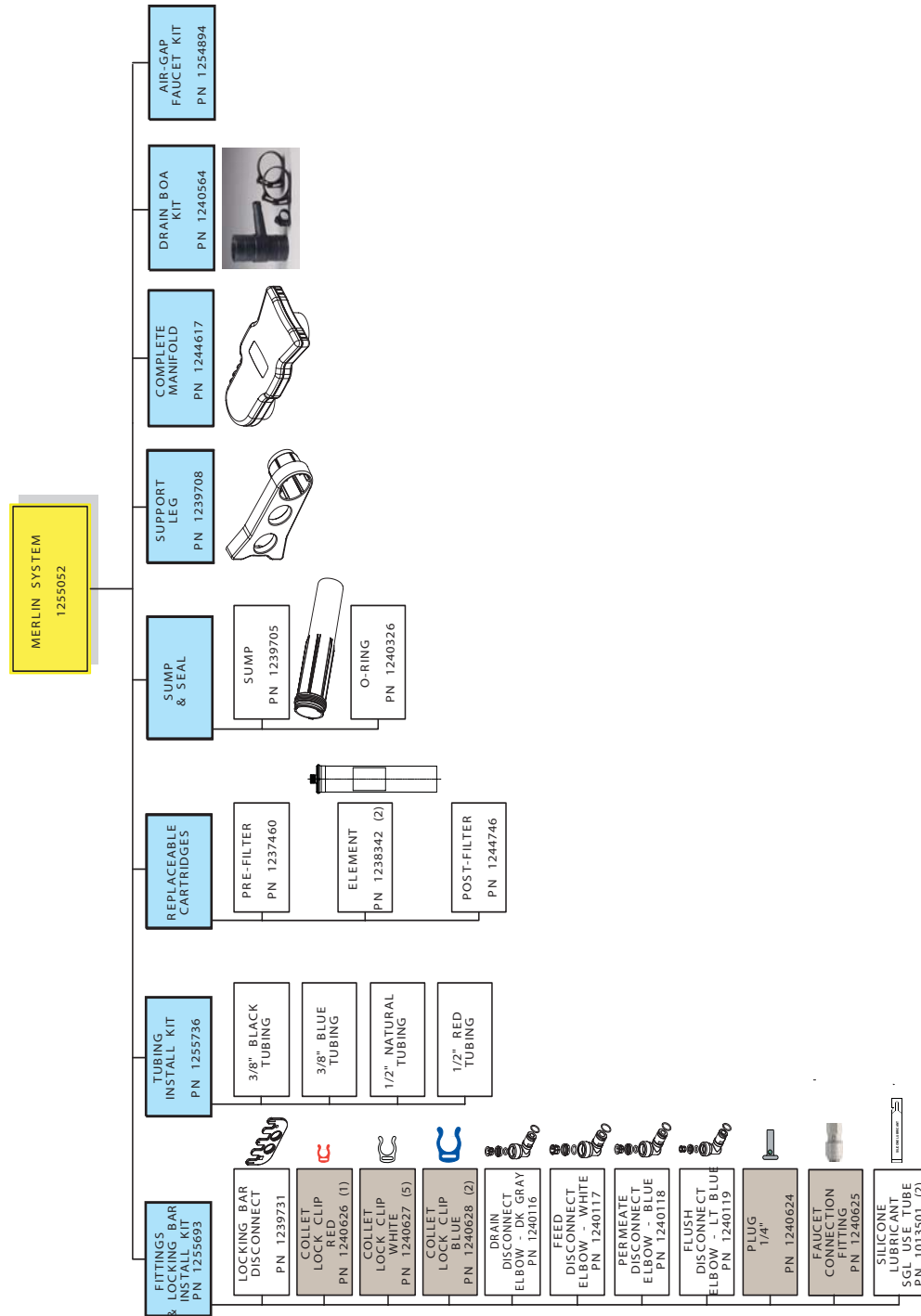

Spare parts are available through your installing water treatment dealer.

MERLIN PARTS LIST

Part Number	Description
I255052	Complete Merlin system
I239705	Sump - interchangeable for all 3 positions
I244617	Manifold - complete
I239708	Support Leg
I240564	Drain Boa Kit
I240620	3/8-inch Black Tubing - 500 foot roll - John Guest Brand
I240621	3/8-inch Blue Tubing - 500 foot roll - John Guest Brand
I240622	1/2-inch Natural (clear) - 250 foot roll - John Guest Brand
I240623	1/2-inch Red Tubing - 250 foot roll - John Guest Brand
I240117	1/2-inch Feed Disconnect Elbow - White
I240118	3/8-inch Permeate Disconnect Elbow - Blue
I240116	3/8-inch Drain Disconnect Elbow - Dark Gray
I240119	1/4-inch Flush Disconnect Elbow - Light Blue
I239731	Locking Bar
I240326	Sump O-Ring
I254894	Airgap Faucet
I255693	Complete Fittings and Locking Bar Kit
I255736	Complete Tubing Install Kit

REPLACEABLE CARTRIDGES

Part Number	Description
I238342	Membrane Element
I237460	Carbon Prefilter
I244746	Carbon Postfilter

Spare parts are available through your installing water treatment dealer.

ACCESSORIES

Part Number	Description
1261345	Merlin Flush Kit (Accumulator tank and 1/4-inch tubing)
1240619	1/4-inch Blue Tubing - 500 foot roll - John Guest Brand
1240632	Inlet Booster Pump, 110V/60Hz
1013501	Silicone Lubricant Pack
1240629	Feed Valve Tee - 1/2" x 1/2" x 1/2" OD Tubing - G.A. Murdock USA
1240630	Feed Valve Tee - 5/8" x 5/8" x 1/2" OD Tubing - G.A. Murdock USA
1262403	Feed Valve Tee - 5/8" x 5/8" x 1/2" OD Tubing -SeaTech
1262404	Feed Valve Tee - 14 mm x 14 mm x 1/2" OD Tubing -SeaTech
1262406	Feed Valve Tee - 15 mm x 15 mm x 1/2" OD Tubing -SeaTech
1262407	Feed Valve Tee - 3/8" x 3/8" threaded x 1/2" Tubing -SeaTech
1262408	Feed Valve Tee - 1/2" x 1/2" threaded x 1/2" Tubing -SeaTech
1262847	10-micron Sediment Prefilter
—	Post Filter Mounting Clip Kit

NON-STOCKED INDIVIDUAL COMPONENTS

Part Number	Description	Recommended Source
1240626	Individual Collet Lock Clip- 1/4-inch Red - John Guest PN PIC1808R-X	John Guest USA
1240627	Individual Collet Lock Clip- 3/8-inch White - John Guest PN PIC1812W-X	John Guest USA
1240628	Individual Collet Lock Clip- 1/2-inch Blue - John Guest PN PIC1816B-X	John Guest USA
1240624	1/4-inch JG Plug - John Guest PN PI0808S	John Guest USA
1240625	Faucet Connection Fitting - John Guest PN CI3212U7S	John Guest USA

Spare parts are available through your installing water treatment dealer.

DIMENSIONS

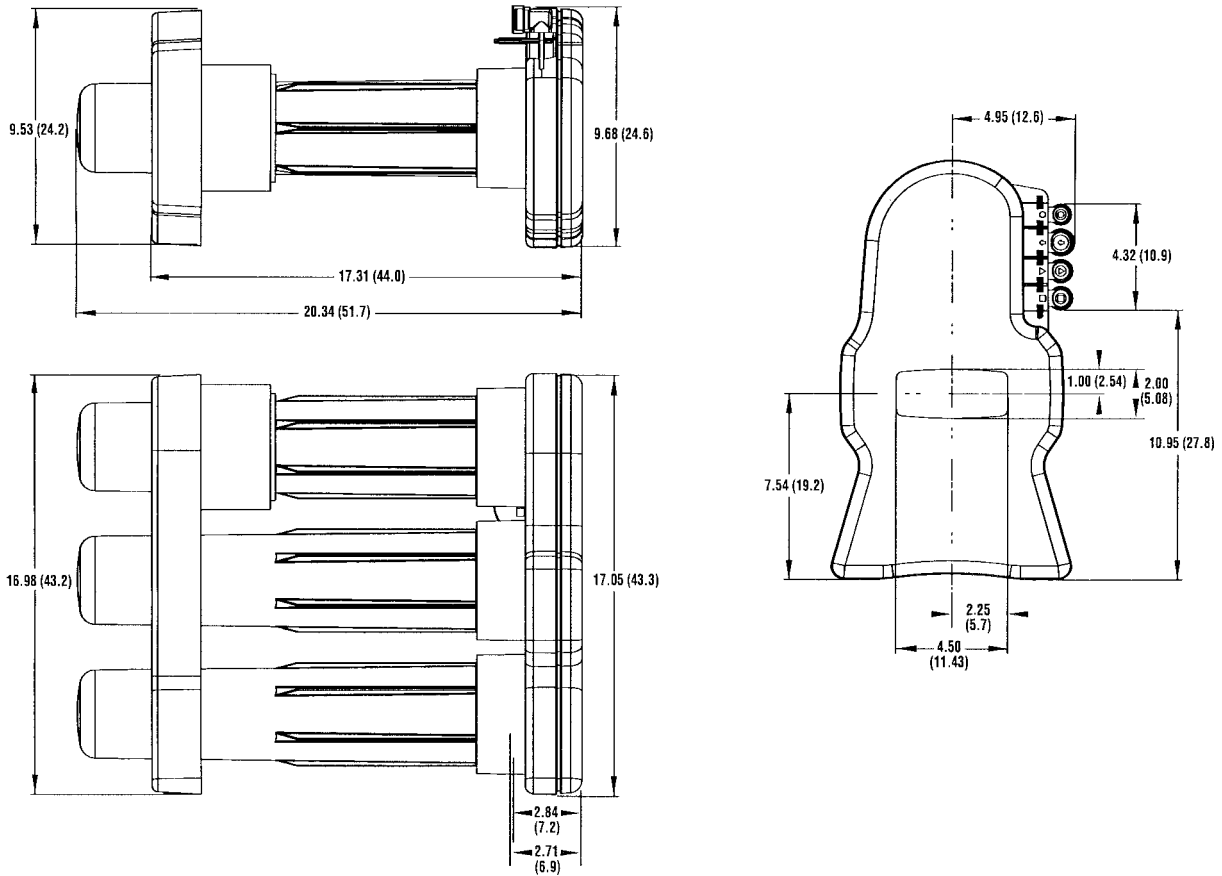

Performance Specifications^{1, 2}

	Minimum	Maximum	Average
Permeate Flow Rate	0.33 gals/min (1.25 Lpm)	0.75 gals/min (2.84 Lpm)	0.50 gals/min (1.89 Lpm)
TDS Rejection (NaCl) ³	90%	99%	93%

Minimum and Maximum Operating Conditions

Condition	Minimum	Maximum
Inlet Pressure	40 psi (2.76 bar)	80 psi (5.52 bar)
Inlet Temperature	40°F (4.44°C)	100°F (37.78°C)
Inlet TDS	50 mg/L	2,000 mg/L
Inlet Hardness	0 mg/L (0 grain)	171 mg/L (10 grain)
Inlet Chlorine	0 mg/L	1.0 mg/L
Inlet Iron	0 mg/L	0.1 mg/L
Inlet Manganese	0 mg/L	0.05 mg/L
Inlet pH	4	10
Inlet Turbidity	0	1 NTU

1. Based on 50 psi (3.44 bar), 77°F (25°C), 750 mg/L NaCl, 23.7% Recovery
2. System is designed for use on potable water systems only.
3. Specifications based on GE Osmonics testing data. For complete WQA test results to ANSI/NSF 58 standard, see the Merlin Performance Data Sheet P/N 1263717.

INSTALLATION INFORMATION AND INSTRUCTIONS FOR [DRAIN-BOA™ MODEL DC9700] DRAIN COUPLING

[Please study all information included before first installation.]

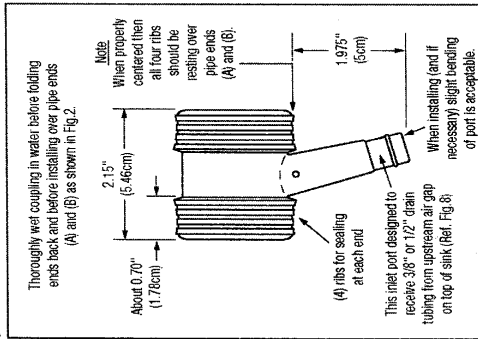

Fig. 1

Drain-BOA™ Rubber Coupling folded back on itself at each end and ready to be installed in the kitchen sink tailpiece
 [Measures just over 2.125\"/>

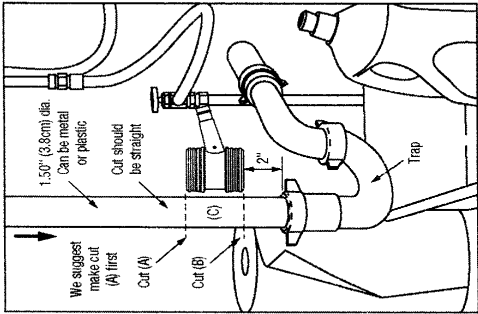

Fig. 2

Typical view under kitchen sink with 1.5\"/>

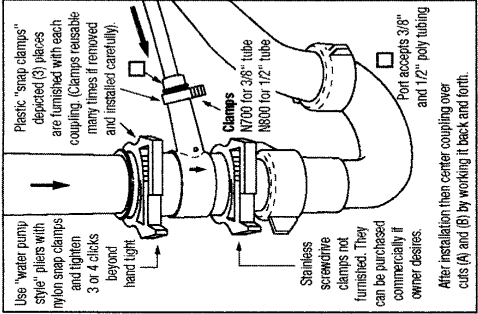

Fig. 3

Typical view of (Fig. 2) plastic tailpiece after installing the Drain-BOA™ Rubber Coupling
 [Polyethylene drain tubing from air gap properly inserted to inner stop and clamped.]
 [Note: Wet tubing only with water before installation.]

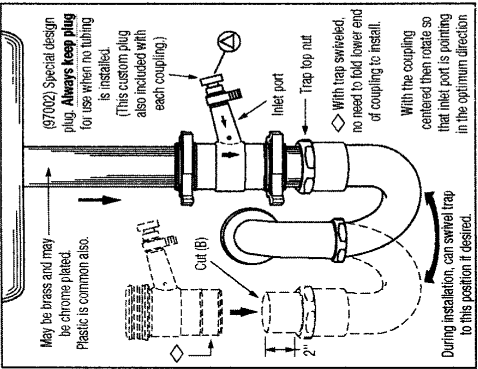

Fig. 4

Depicts metal 1.5\"/>

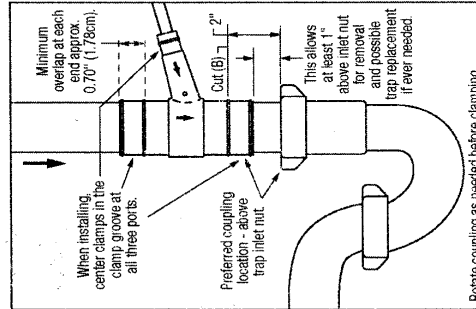

Fig. 5

This coupling depicted before the clamps are installed.
 [If large stainless screw drive clamps are used (ref. Fig. 6), their width must be 0.50\"/>

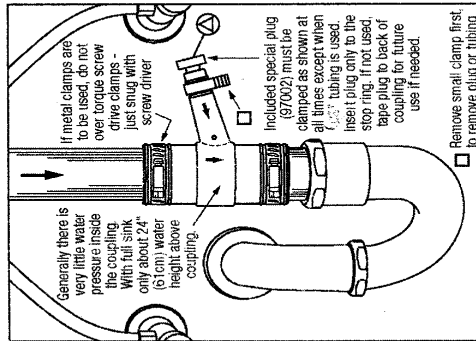

Fig. 6

Depicts Drain-BOA™ coupling installed with stainless steel screw drive clamps on the large ports.
 [Either tubing or solid plug (97002) must be installed at all times, otherwise leakage will occur out this port.]

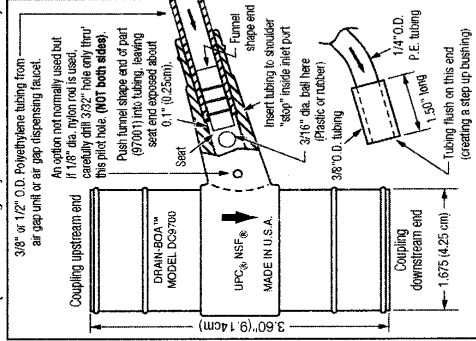

Fig. 7

Depicts certain dimensions and marking. Cut 3/8\"/>

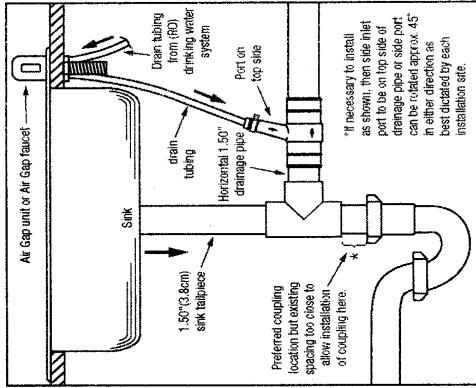

Fig. 8

Depicts Drain-BOA™ coupling installed in a horizontal branch below kitchen sink, due to space limitations at the preferred installation site.
 [Always install unit according to flow arrows.]

SPECIFIC CONTAMINANT PERFORMANCE

Contaminant	Influent (avg. mg/L)	Effluent (ave. mg/L)	Effluent (max. mg/L)	Ave % Reduction
Arsenic ^a	0.049	0.00265	0.00612	94.6%
Barium	11.1	0.189	1.9	98.3%
Cadmium	0.0307	0.0000704	0.0000704	99.8%
Chromium (VI)	0.353	0.00742	0.0147	97.9%
Chromium (III)	0.312	0.000624	0.00453	99.8%
Copper	3.22	0.0721	0.0721	97.8%
Fluoride	8.11	0.51	0.65	93.7%
Lead	0.159	0.000628	0.000628	99.6%
Nitrate/Nitrite (as N) ^b	28.96	6.26	7.55	78.4%
Radium 226/228				
Selenium	0.113	0.00249	0.003	97.8%
Total Dissolved Solids (TDS)	726	74.8	94.8	89.7%

a. This system has been tested for the treatment of water containing pentavalent arsenic (also known as As(V), As(+5), or arsenate) at concentrations of 0.050 mg/L or less. This system reduces pentavalent arsenic, but may not remove other forms of arsenic. This system is to be used on water supplies containing a detectable free-chlorine residual at the system inlet or on water supplies that have been demonstrated to contain only pentavalent arsenic. Treatment with chloramines (combined chlorine) is not sufficient to ensure complete conversion of trivalent arsenic to pentavalent arsenic. Please see the Arsenic Facts section of the Merlin system performance data sheet.

b. This system is acceptable for treatment of influent concentrations of no more than 27 mg/L nitrate and 3 mg/L nitrite in combination measured as N and is certified for nitrate/nitrite reduction only for water supplies with a pressure of 40 psi (2.76 bar) or greater.

To verify the level of nitrate/nitrite in the product water use the test strips that have been included with the system. Follow the instructions that are on the test strip packaging.

The level of nitrate/nitrite in the product water should be within local standards before placing the Merlin system into operation.

Testing performed under standard laboratory conditions. Actual results may vary.

SYSTEM PERFORMANCE RATING:

Product Water Production:	748 Gallons perday (2,831 Liters per day)
Average System Recovery:	23.70%
Average System Efficiency:	23.70%

Average System Recovery means the percentage of the influent water to the membrane portion of the system that is available to the user as reverse osmosis treated water when operated as designed (without a pressurized storage tank).

Average System Efficiency rating means the percentage of the influent water to the system that is available to the user as reverse osmosis treated water under operating conditions that approximate typical daily usage.

Efficiency rating is identical to recovery rating when the system is tested without a storage tank or when a storage tank is bypassed.

SYSTEM SPECIFICATIONS AND OPERATING PARAMETERS

Minimum and Maximum Operating Conditions

Inlet Water Condition	Minimum	Maximum
Pressure	40 psi (2.76 bar)	80 psi (5.52 bar)
Temperature	40°F (4.44°C)	100°F (37.78°C)
TDS	50 mg/L	2,000 mg/L
Hardness	0 mg/L	171 mg/L
Chlorine	0.0 mg/L	1.0 mg/L
Iron	0.0 mg/L	0.1 mg/L
Manganese	0.0 mg/L	0.05 mg/L
PH	4.0	10.0

Actual system performance will vary depending on varying water temperature and pressure, TDS levels and inlet water chemistry. Operating the system in water conditions outside the minimum or maximum operating parameters may result in reduced system performance and membrane element life.

System manufactured by:

GE Infrastructure
Water & Process Technologies
5720 N. Glen Park Road
Milwaukee, WI 53209-4454
U.S.A.

Direct spare parts and service inquiries to the system's installing dealer.

Contact your installing dealer for spare parts or service:

